

APPROVAL SHEET

SPECIFICATIONS OF HUAYI R134a COMPRESSOR

MODEL NAME: E75H

BUYER:

PRINTED DATE: October 15, 2019

MANUFACTURER

HUAYI COMPRESSOR (JINGZHOU) CO., LTD.

华意压缩机(荆州)有限公司

SPECIFICATION

● CUSTOMER:

FROM: HUAYI COMPRESSOR (JINGZHOU) CO., LTD.

● MODEL: E75H

华意压缩机(荆州)有限公司

DATE: October 15, 2019

● RATED VOLTAGE & FREQUENCY: 220-240V/50Hz

PREPARED	CHECKED	APPROVED
Wang Zhongwei	Fan HongXing	Zhang Changxiang

● SPEC. NO.:

● PARTS LIST

PART LIST		HUAYI SUPPLY	PART NO.	QTY	SPECIFICATION
COMPRESSOR	PERFORMANCE				
COMPRESSOR	WIRING DIAGRAM				
COMPRESSOR	EXPLODED VIEW				
ELECTRICAL PARTS	OLP + Spring taps			1	DRB174N61A2/BT42-120A61D3/BT42-120 (081)
ELECTRICAL PARTS	STARTING DEVICE			1	QP2-22/QP2-22/JPQ II -22 (015)
ELECTRICAL PARTS	RUNNING CAPACITOR			1	10 μ F (5 μ F)
ELECTRICAL PARTS	TERMINAL COVER + SPRING TAPS			1	PC, SPRING STEEL
ELECTRICAL PARTS	EARTH BOLT			1	
MOUNTING PARTS	SEAT RUBBER			4	
MOUNTING PARTS	MOUNTING SLEEVE			4	
MOUNTING PARTS	FLAT WASHER			4	

CUSTOMER' S MEMO

CUSTOMER' S APPROVAL

Checked by:

Approved by:

*Please return one copy of this page on your approval.

20191015-E75H

4-1

Performance & Dimension

Application

Type	Low Back Pressure
Evaporating Temp. Range...	-35°C to -15°C(-31°F to 5°F)
Refrigerant.....	R134a
Refrigerant control.....	Capillary tube
Compressor cooling	Static cooling

Normal Performance (ASHRAE) 50Hz

Capacity	Watt±5%	180
	Kcal/h±5%	154.8
	BTU/h±5%	614.2
Power consumption	W+15%	120
C. O. P.	W/W±5%	1.50
EER	BTU/(W. h) ±5%	5.12
NOISE	dB(A)	45

Testing condition

Evaporation Temp.	-23.3°C (-10°F)
Condensing Temp.	54.4°C (130°F)
Ambient Temp.	32.2°C (90°F)
Return Gas Temp.	32.2°C (90°F)
Liquid Temp.	32.2°C (90°F)

Compressor Date

Design.....	Reciprocating
Displacement.....	7.0cm ³

Suction Tube I.D.....	I. D φ 6.10 ~ φ 6.20mm
Process Tube I.D.....	I. D φ 6.10 ~ φ 6.20mm
Discharge Tube I.D.....	I. D φ 4.90 ~ φ 5.00mm

Weight(with oil charge)..... 8.0Kg

Motor Date

Motor type	RSCR
Motor protection.....	External protection
Winding Insulation Class	E Class

EXPLODED VIEW

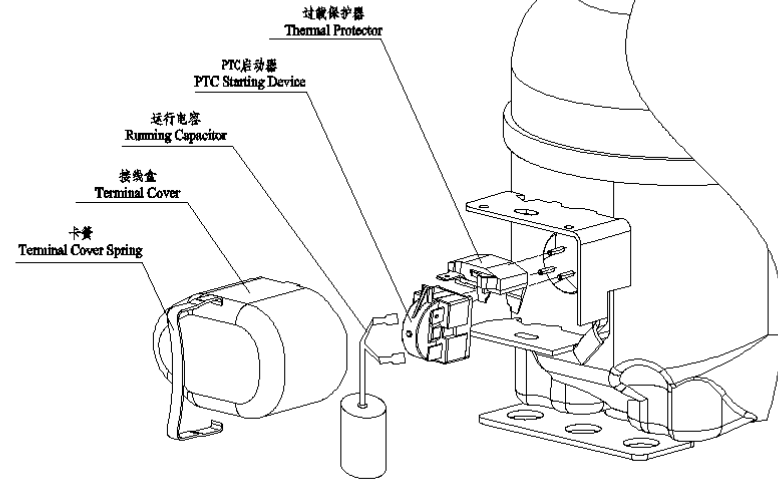

OVERALL DIMENSION

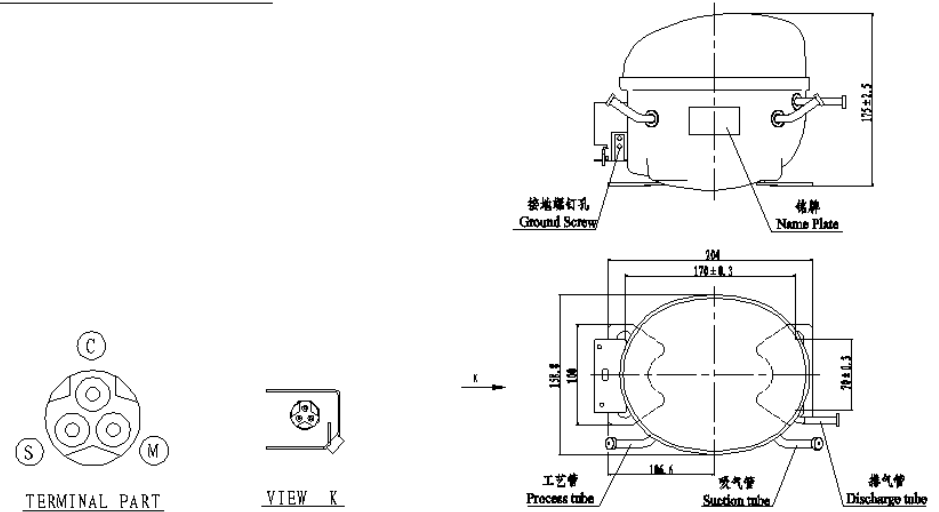

Electrical components

Overload protector..... DRB174N61A2/BT42-120A61D3/BT42-120

Ultimate Trip current (at 90°C)..... 1.1~1.6A

Opening temperature..... $120 \pm 5^\circ\text{C}$

Closing temperature..... $61 \pm 9^\circ\text{C}$

Manufacture..... Star Shuaier/Sen Bao/Lan Xi

Starting Device QP2-22/QP2-22 /JPQ II -22

Manufacture Star Shuaier/Sen Bao/Lan Xi

Running Capacitor Capacity $10 \mu\text{F}$ ($5 \mu\text{F}$)

Voltage..... 450V

Starting Capacitor Capacity..... N.A.

Voltage..... N.A.

Lubricant

Lubricant type..... Polyol Ester (POE)

Lubricant Viscosity at 40°C

Domestic..... RB-15HY-SN

Export..... RB-15HY-SN

Initial charge $250 \pm 10\text{ml}$

Recharge 85%

Tray Holder N.A.

Earth plate..... N.A.

Approved Certification..... N.A.

Wire Drawing

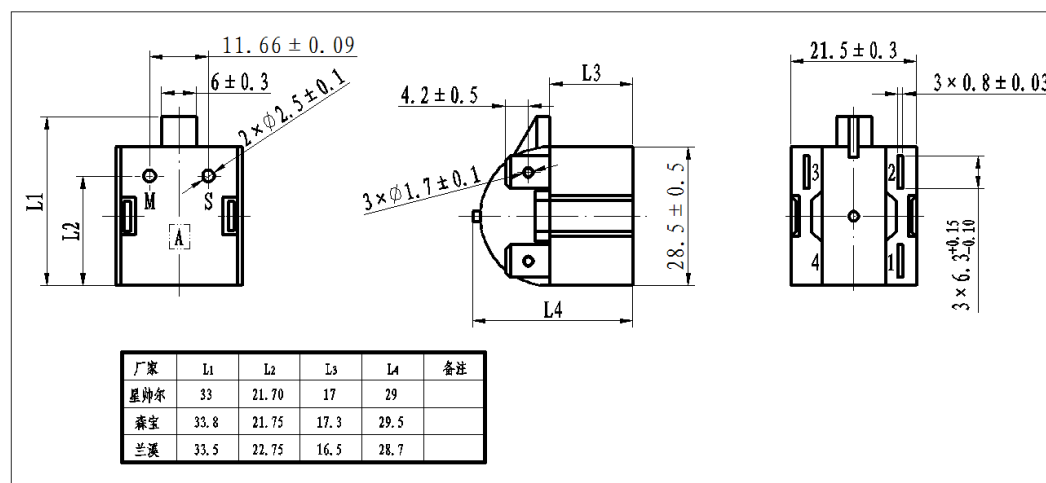
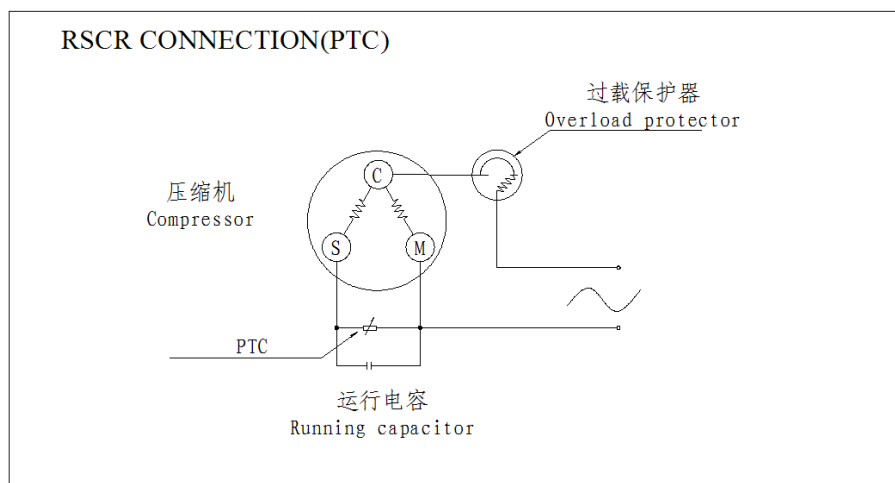
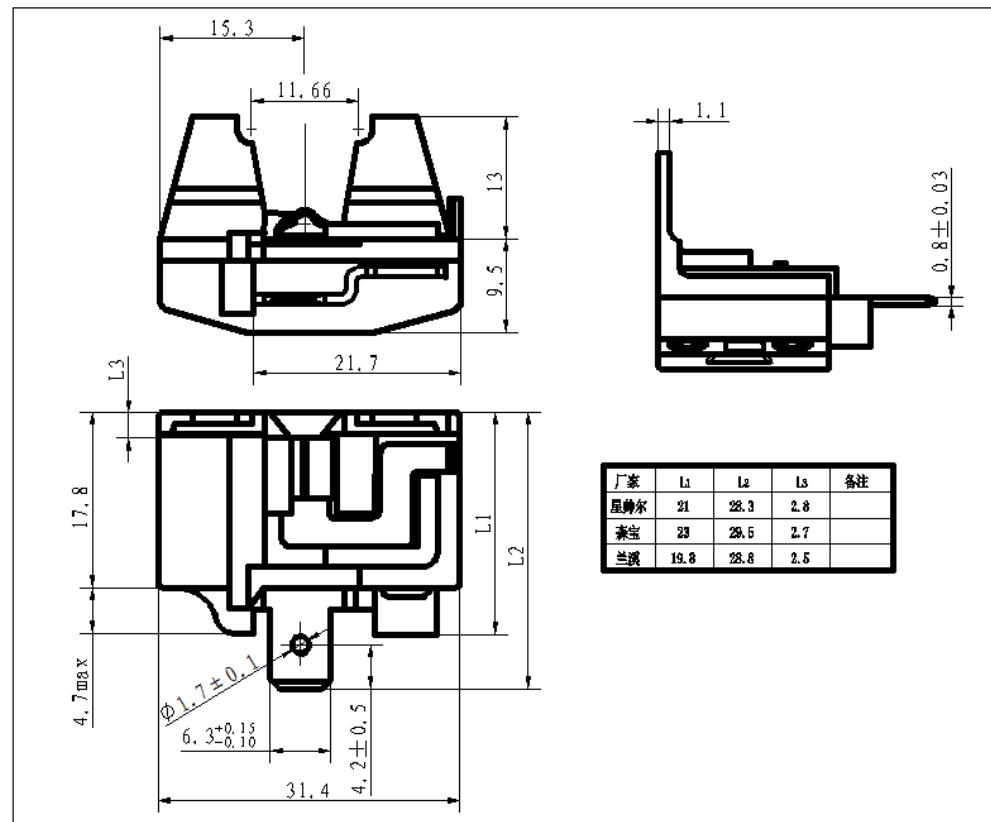

Cover & Accessories

